

REVISIONS

ZONE	REV	DESCRIPTION	DATE	APPROVED

6 X 8.2 # CHANNEL X 25 1/2 LONG
LEGS UP--SIX PLACES

1 1/2 X 1 1/2 X 3/16 ANGLE

3 X 2 X 1/4 ANGLE

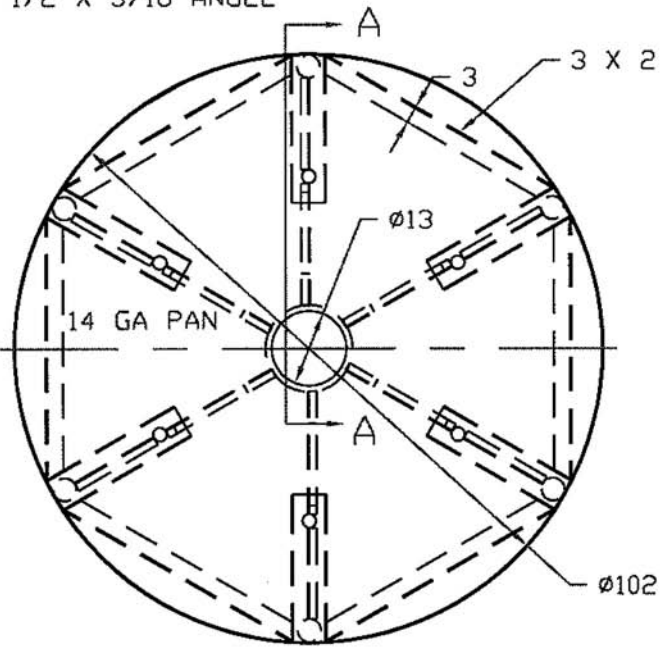
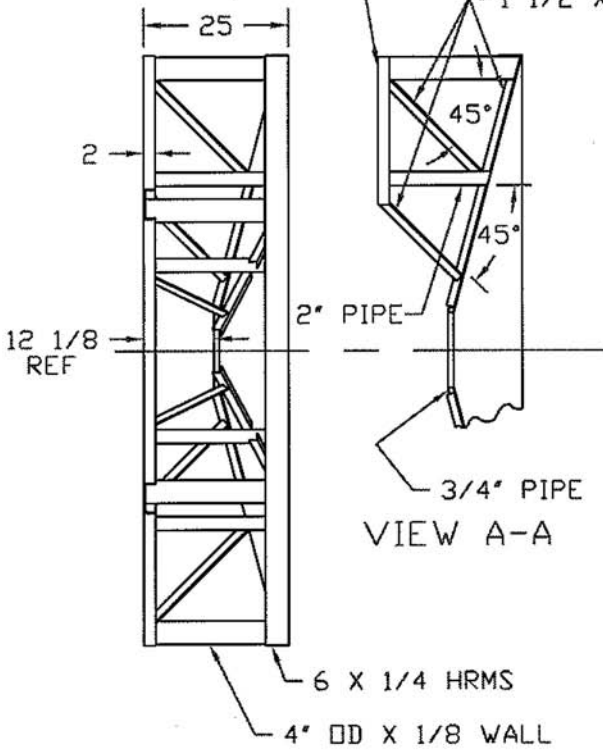

Ø102



STEEL STAND, 6000 GAL
CONE BOTTOM TANK

JTP	09NOV99	SIZE B	FSCM NO.	DWG NO.	REV
-----	---------	-----------	----------	---------	-----

SCALE 1/24

SHEET