



Newly Designed and Improved Gemini G10² **Better Design – More Features – Same Price**

July 31, 2015

Dear Customer,

Congratulations on purchasing a G10², The finest dual containment tank available anywhere. Gemini Tanks are designed with your needs in mind, with standard features not available on other similar products.

The tank you have just received is our new design, which has been improved based upon feedback from our most valued product development team; YOU, our customer!!!

This **NEWLY DESIGNED TANK** is slightly different than our 1.0 version you may have received in the past. We have added a couple of new features to make it work even better than before for your day to day operation.

The new features on this version include:

- **Large corner port for a leak detection sensor in the containment tank.** We replaced the ¼" leak detection port on the side of the top with a ¾" port in the corner and added a faceted corner on the inner tank for a clear path to the tank bottom. (we have a leak detection sensor available if you're interested – ask your customer service representative). It's now large enough to visually assess the containment area as well.
- **Slightly Taller design – increased capacity** – It's about 1-1/2" taller to allow for the increased area for leak detection in the corner.
- **Glass Bead Finish** – Smooth, velvety surface to accommodate decal placement and adhesion quality.

Other than that, it's the same as the old model. We hope you like the changes and appreciate any feedback on this or any other Peabody Product. Our goal is to provide the **BEST PRODUCTS AVAILABLE ANYWHERE!** We couldn't do that without the great feedback we get from customers like YOU!!! **By the way, we also have a new G5² too! Ask your Peabody Representative for more information.**

Thanks for Purchasing Peabody Tanks! We appreciate your Trust and Confidence in our products.

D

C

B

A

D

C

B

A

3/4" SPINWELD, (FNPT)
INTERSTITIAL ACCESS

RED CAPPLUG

2" SPINWELD
(FNPT)

4" TWIST LID

PUMP SUCTION
CONNECTION
FOR MAX 3/8" O.D.
SUCTION TUBING

PLAN VIEW

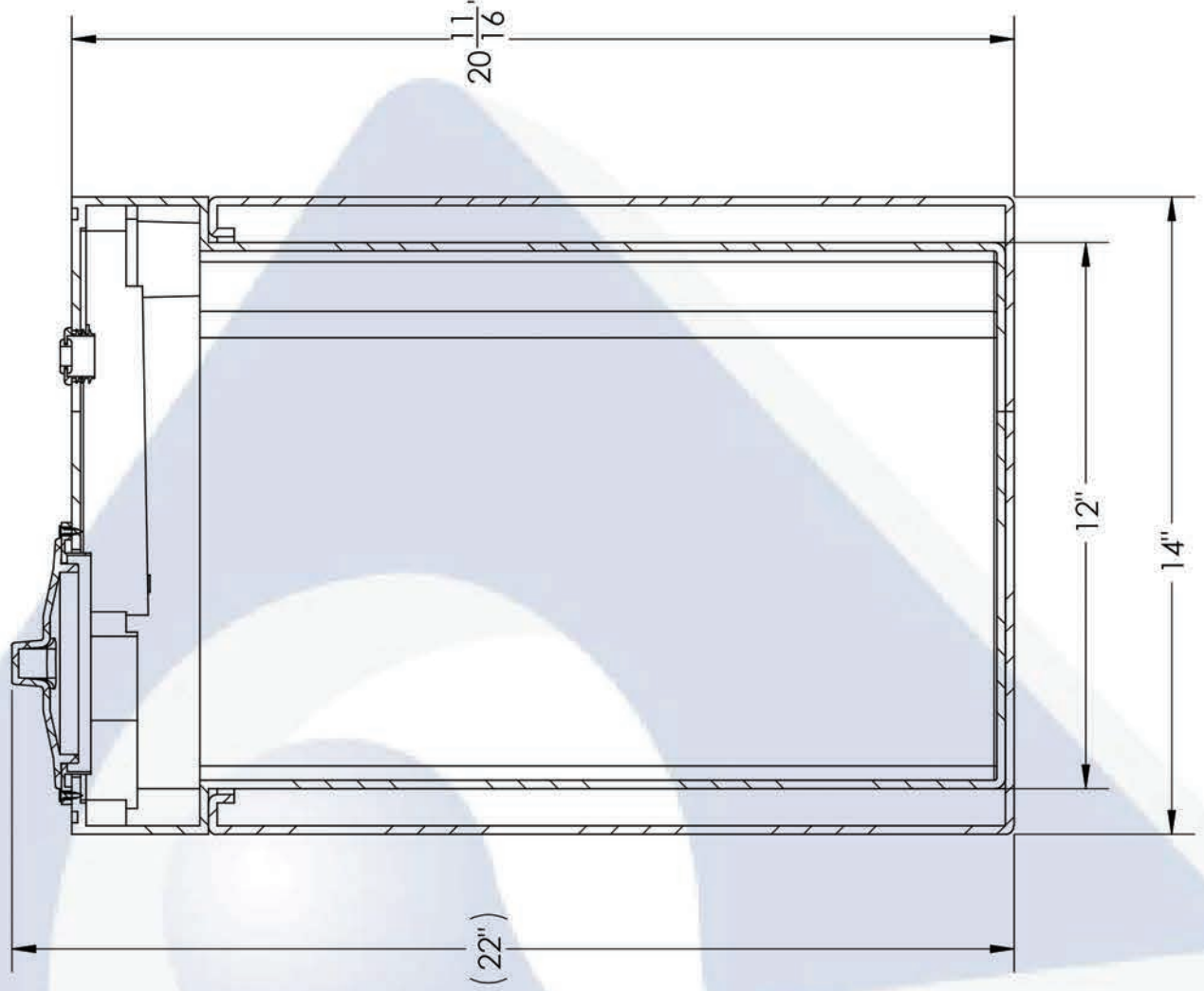
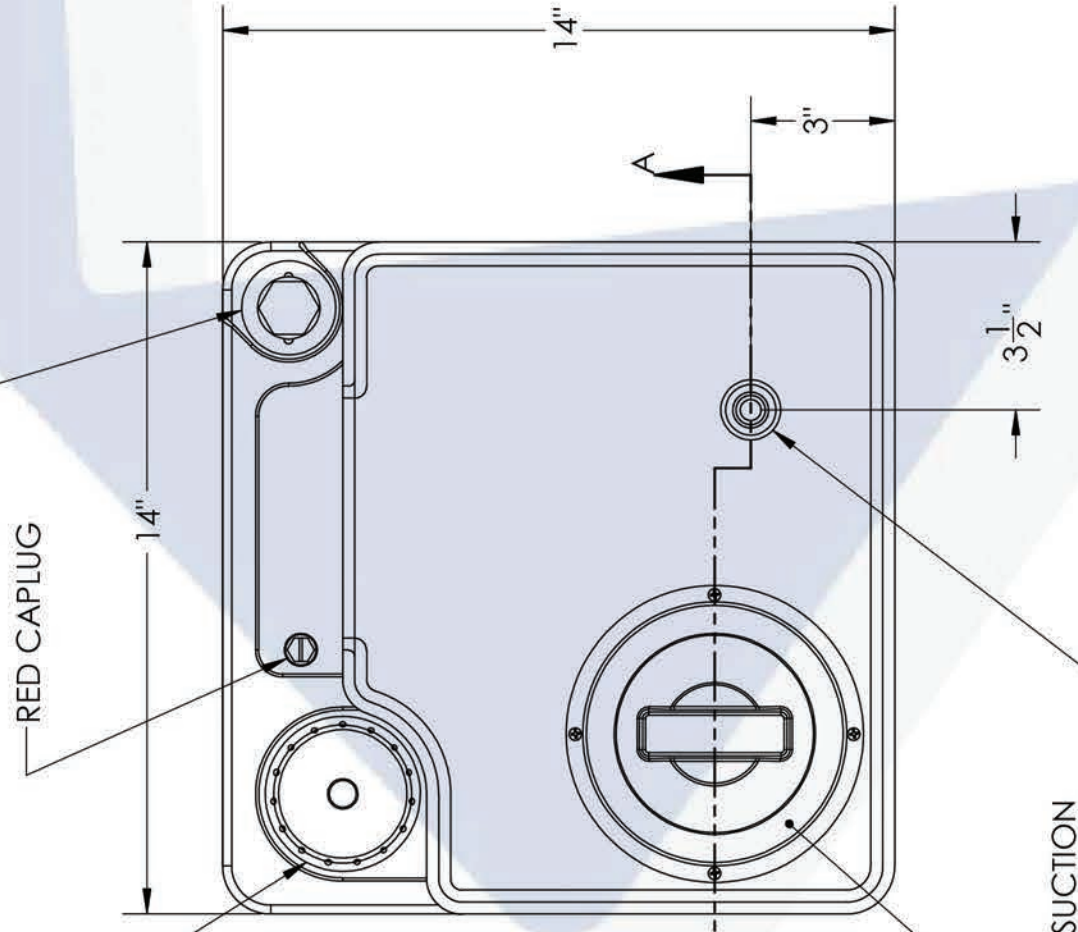

SECTION A-A



PROJECT: 10G GEMINI², ASSEMBLY, REV D

SCALE: 1:4 SHEET 2 OF 2

1 2 3 4 5 6 7 8

1 2 3 4 5 6 7 8